

unicef   
for every child

Accelerated  
Learning  
Programme

# ALP PHYSICS

Glossary for all Units,  
and the full text  
of the Unit “Electrical Current”,  
translated in English



Funded by the  
Asylum, Migration and  
Integration Fund of the  
European Union



ΠΑΝΕΠΙΣΤΗΜΙΟ  
ΘΕΣΣΑΛΙΑΣ



# ALP PHYSICS

Glossary for all Units,  
and the full text  
of the Unit “Electrical Current”,  
translated in English



Funded by the  
Asylum, Migration and  
Integration Fund of the  
European Union



ΠΑΝΕΠΙΣΤΗΜΙΟ  
ΘΕΣΣΑΛΙΑΣ





**ΕΡΓΟ ALP**

**ΦΥΣΙΚΗ**

**ΣΥΓΓΡΑΦΕΑΣ ΕΚΠΑΙΔΕΥΤΙΚΟΥ ΥΛΙΚΟΥ**

ΙΛΙΑ ΧΡΙΣΤΙΔΟΥ

Αναπληρώτρια Καθηγήτρια Αριστοτελείου Πανεπιστημίου Θεσσαλονίκης

**ΜΕΤΑΦΡΑΣΗ ΣΤΑ ΑΓΓΛΙΚΑ**

ΑΧΙΛΛΕΑΣ ΚΩΣΤΟΥΛΑΣ

Μέλος ΕΔΙΠ ΠΤΔΕ Πανεπιστημίου Θεσσαλίας

**ΕΙΚΟΝΟΓΡΑΦΗΣΗ**

ANNA ΠΑΠΑΪΩΑΝΝΟΥ

**ΕΠΙΣΤΗΜΟΝΙΚΑ ΥΠΕΥΘΥΝΟΣ ΕΡΓΟΥ ALP**

ΓΙΩΡΓΟΣ ΑΝΔΡΟΥΛΑΚΗΣ

Διευθυντής του Εργαστηρίου ΜΔΔ Ελληνικής Γλώσσας και Πολυγλωσσίας  
Πανεπιστήμιο Θεσσαλίας

**ΥΠΕΥΘΥΝΟΙ ΓΙΑ ΤΗ UNICEF**

ΝΑΟΚΟ ΙΜΟΤΟ

ΓΙΩΡΓΟΣ ΣΙΜΟΠΟΥΛΟΣ

**ΕΚΠΡΟΣΩΠΟΣ ΓΝΩΜΟΔΟΤΙΚΗΣ ΕΠΙΤΡΟΠΗΣ ΙΕΠ**

ΝΤΟΡΕΤΤΑ ΑΣΤΕΡΗ

**COPYRIGHT** ©

2020, UNICEF & GLML, UNIVERSITY OF THESSALY



# TABLE OF CONTENTS

**Unit 9. Electrical current.....7**

**Glossary ..... 31**



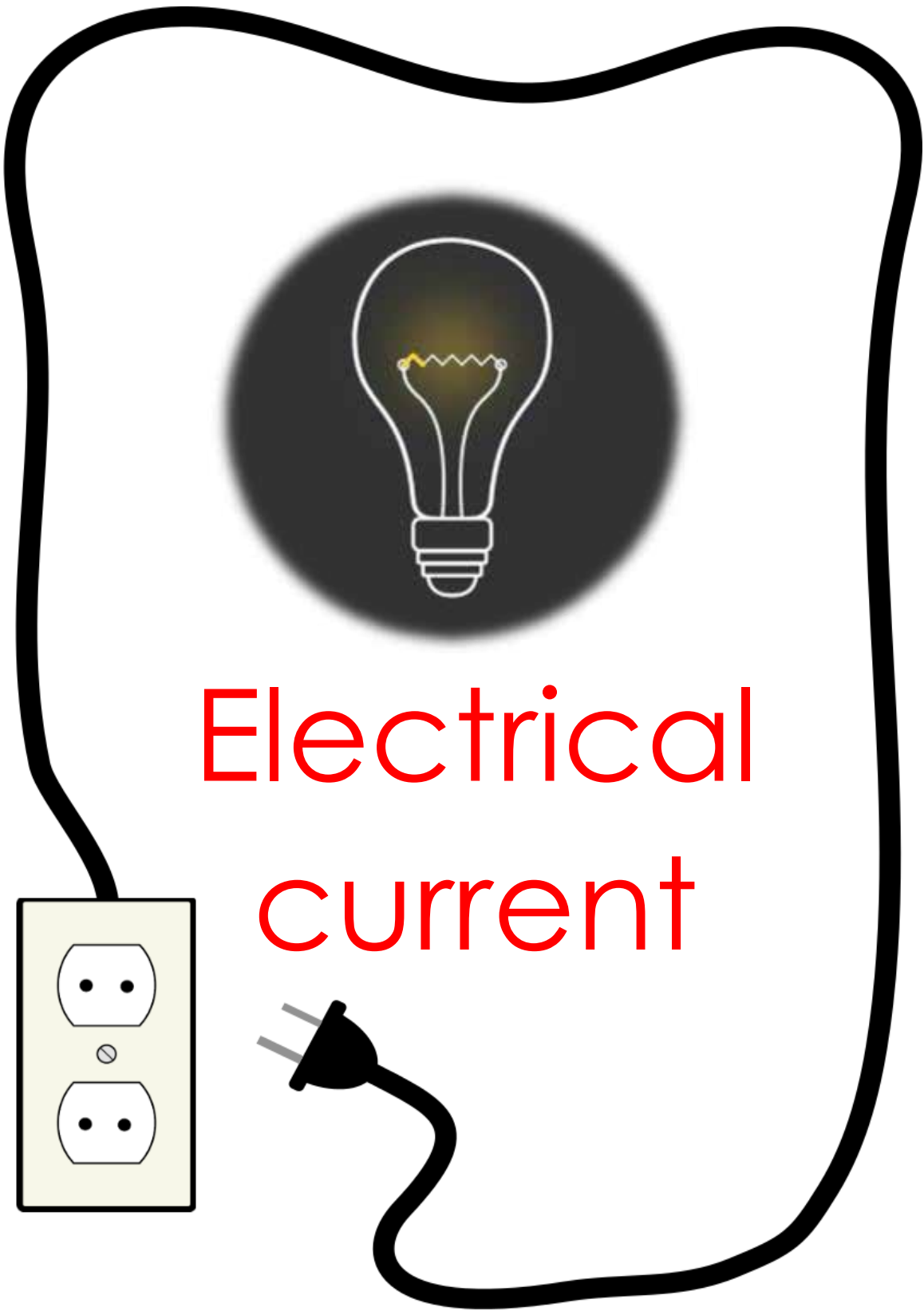

Electrical  
current



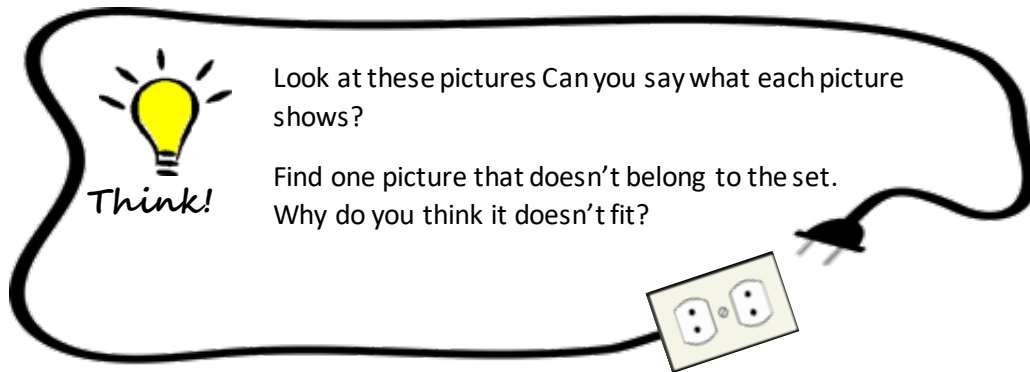

Many of the things we use every day run on electricity.

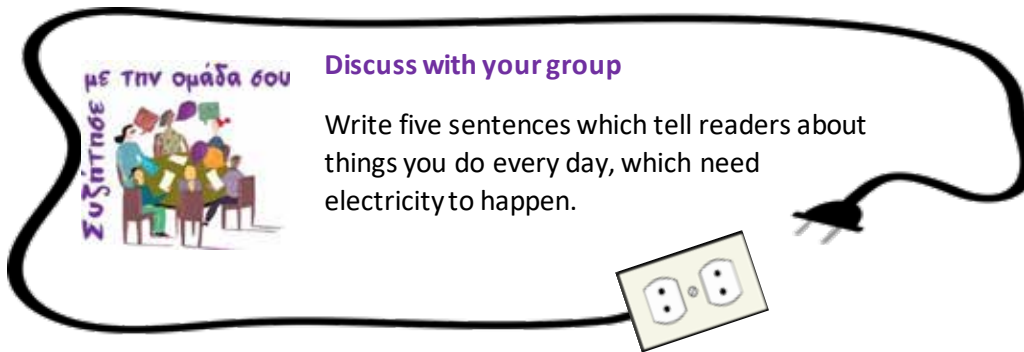

We live in an electrical world! Many of the things that we use every day need electricity to work. Your computer runs on electricity. The stove and the fridge in your kitchen run on electricity too. So do the lights in our house and at the street. Electricity runs through the cables that we find in our houses and in our towns.

## What is electricity?



**Remember!**

Things around us are made of a very large number of atoms. There's a nucleus inside each atom. This is made of protons and neutrons. Protons carry a positive (+) charge. Neutrons do not carry a charge. The total charge of a nucleus is positive (+). The nucleus stands still at the centre of the atom. Electrons orbit around it. Electrons have a negative (-) charge.



Neutron

Electron

Nucleus

Proton

*An atom has a positively charged nucleus, and negatively charged electrons*

**Electricity** is named after **electrons**. An **electrical current** is tiny negative charges moving in the same direction.

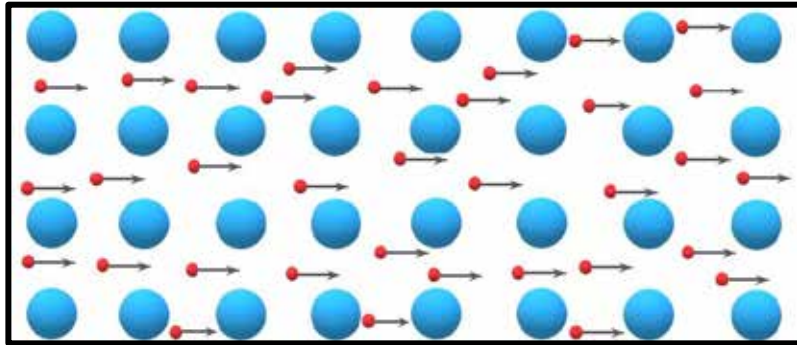

*An electrical current is tiny negative charges moving in the same direction.*

An electrical current is like a river. A river is water that flows from a mountain towards the sea. In the same way, an electrical current is electrical charges ‘flowing’ in the same direction through a conductor.

The electrical charges that are easiest to move are electrons. This cannot happen in all the materials though. The materials that let electrons move easily are called **conductors**. Metals, like iron, copper, and aluminum are the best-known conductors. We use such metals to make the wires in electrical devices.



*Copper electrical wires*

When electrons are far from the atom’s nucleus in a conductor, then it is easy for them to escape. When that happens, these electrons travel from one end of the conductor to the other one. We call these electrons *free electrons*. Atoms that have lost their free electrons are positively charged; scientists call them *positive ions*. Positive ions are large and heavy. That is why they remain in place.

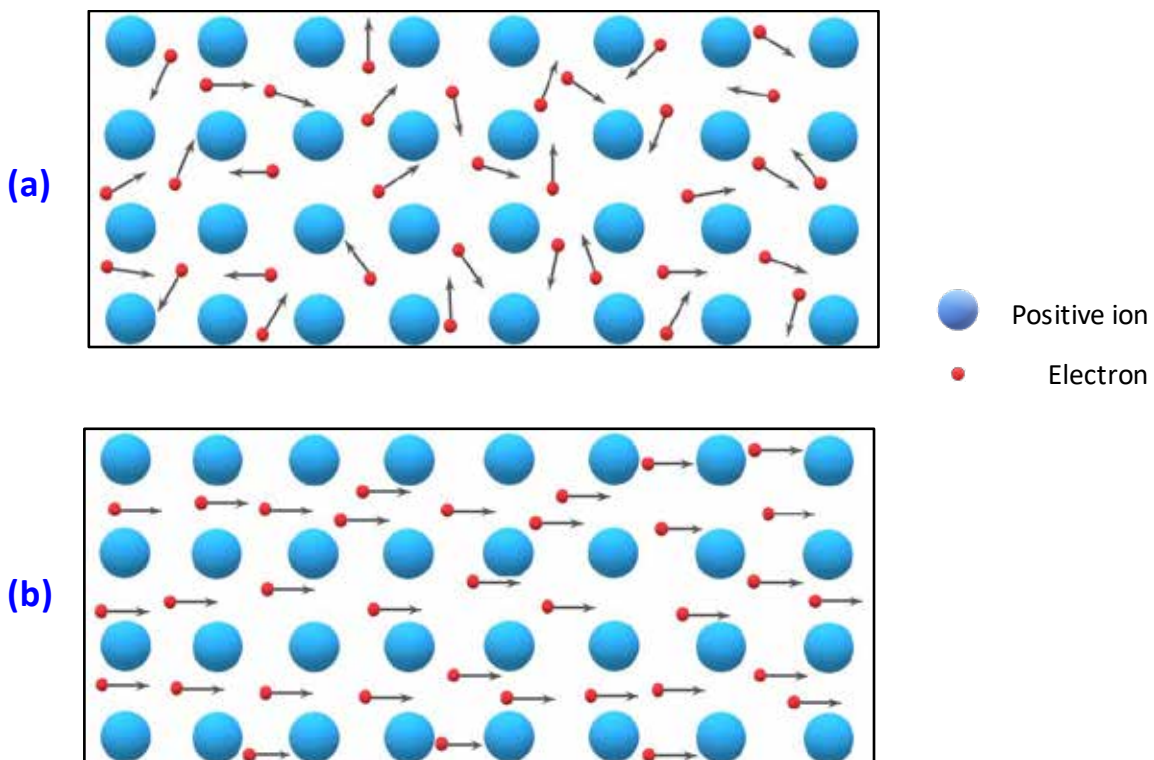
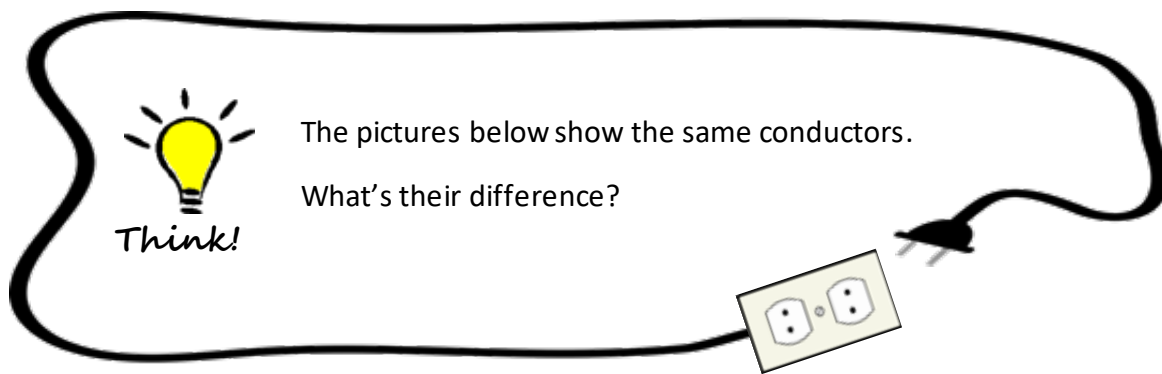

*Free electrons moving among positively charged ions in a disordered way (picture a) and in an oriented way (picture b)*

The difference between the conductors in the pictures above is that electrons are moving in a disordered way in picture (a), i.e., they are moving in all direction. **There is NO electrical current** in conductor (a). On the other hand, all the electrons in conductor (b) are flowing in the same direction. This is an *directed* movement. **There is electrical current** in conductor (b).

### What does it take to have an electrical current?

An electrical current needs a road, a path for the electrons. We call this path a circuit. Every device has an electrical circuit. A fridge, a stove, an electrical fan, a computer, all have electrical circuits.

A circuit looks like a model railroad. In a model railroad, trains run on tracks. In the same way, electrons in a circuit run through a wire, i.e., a conductor. Carriages in a model railroad are pulled by an engine. In the same way, electrons in a circuit are 'pushed' by a battery.

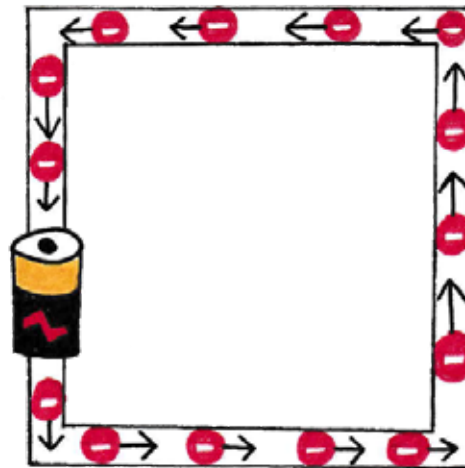

*An electrical current is like a model railroad  
(click on the picture to see the train move)*

### Remember!

A battery provides *energy* to the electrons in a conductor and this makes it possible for them to move. A battery is a **source**. There are two sides, or *terminals*, in a battery. One terminal is positive (+) and the other one is negative (-). The charge of the positive (+) pole pulls electrons (-) towards it. That's how a positive pole makes a current flow inside a conductor. In the picture above, write the symbol + on the battery's side that you think is the positive terminal; write the symbol - on the side that is the negative terminal.

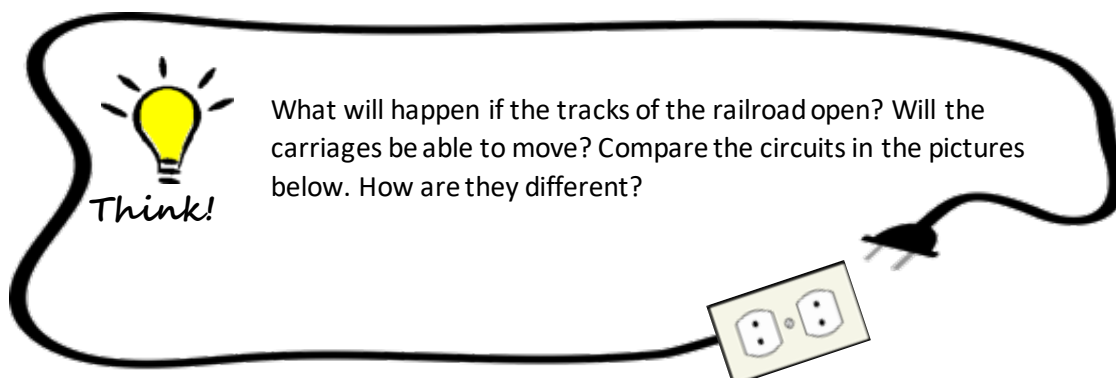
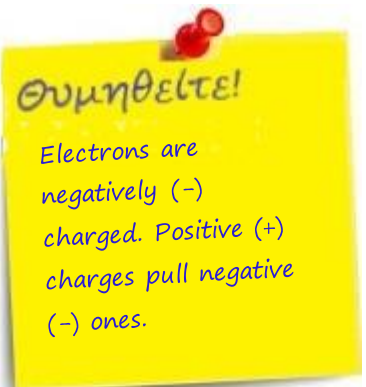

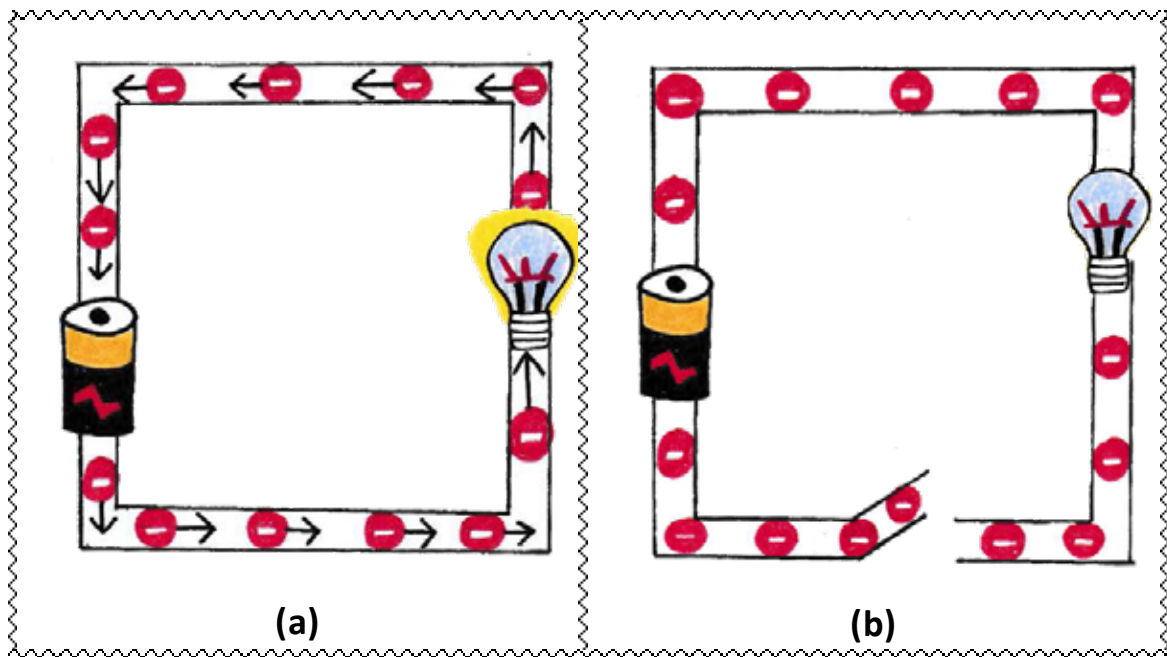

(a) (b)  
A closed circuit (a) and an open one (b)

 **Let's write down our conclusion**  
Choose the right word to complete the following sentence:

open       closed

For electrical current to flow in a circuit, this circuit must be a ..... circuit.

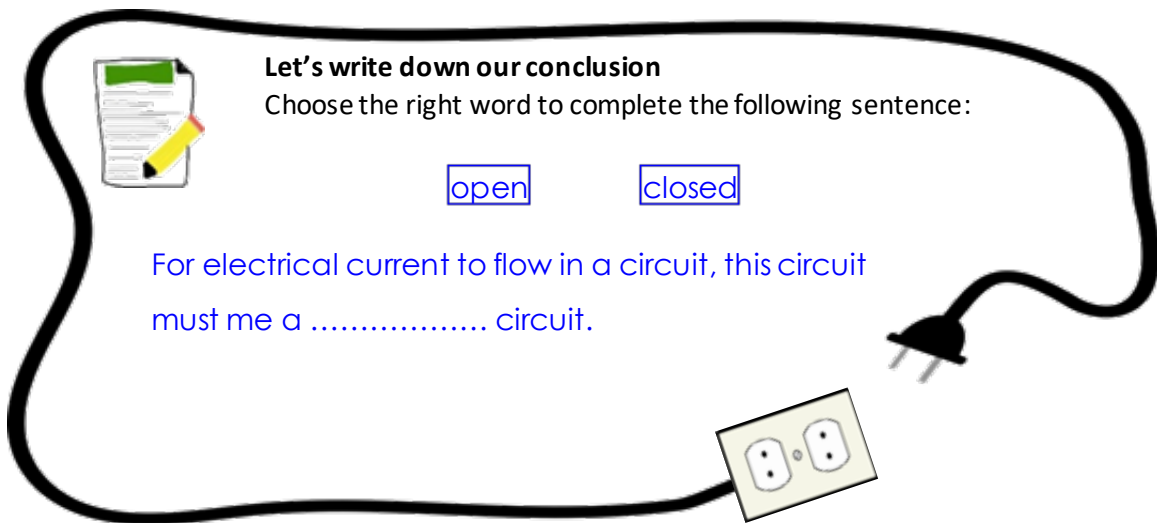

If the tracks in a model railway open, then the carriages can no longer run. The same happens with circuits. If a circuit opens, then the electrons can no longer flow. In the picture below, draw arrows to symbolize the irregular movement that electrons make in an open circuit, as we say above.

We do not want electrical devices to run (work) all the time. That is why the circuits in such devices have *switches*. A switch opens (breaks) or closes a circuit. When a switch breaks a circuit,



the electrical current stops. Then the device stops running. When a switch shuts the circuit, then the electrical current flows again. Then the device runs.

















*Switches like the ones in our homes*

The following are often found in a circuit:

- Conductors, such as wires;
- A source, like a battery or a power outlet on the wall;
- Something that works by using the electrical current, e.g, a light bulb;
- A switch, so that we can open or shut the circuit.

Scientists use symbols to draw all these components of an electric circuit. You can see what is in a simple circuit with a battery in the table below. The first column of the table uses words to list the components of a circuit. The second column shows their pictures, just as we see them in real life. The third column shows their pictures, just as we saw them above. The fourth column shows the symbols that scientists use to draw the same things.

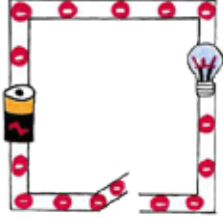
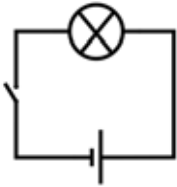
What is there in an electrical circuit?

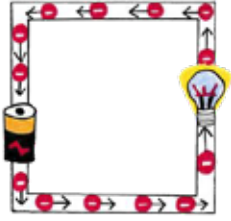
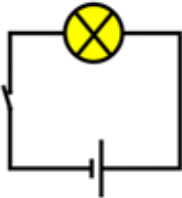
Name	Everyday picture	Picture used here	Symbol
Conductor (wire)			
Source (battery)			
Light bulb			
Switch			
Open circuit			
Closed circuit			





**TRY AN EXPERIMENT!**

Click [here](#) to visit a virtual electricity lab.



Click on this picture:

- Using what you can see in the left side of the screen, build your own circuit. Does the lightbulb light up? Try to make it light up\*.

\*Note: just like batteries, lightbulbs have two terminals. To make them light up, **both** terminals must be connected to a **wire**.

- Circle the words that describe what you see when your circuit is closed:

battery      switch      washing machine      light bulb  
 electrons      train      electrical current      wire      positive ions

- Click on this symbol  to open the switch. What has changed? Complete the sentence with the missing words:

When a switch opens, the circuit is .....

Electrons ..... The light bulb .....

.....

- Click on this symbol  on the right side of the screen, to see your circuit in symbols.

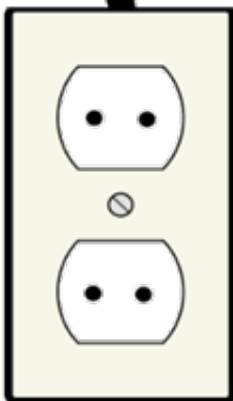

## Are all electrical currents the same?

Look at the picture below. It shows cross-sections from two wires (conductors) which have electrical currents. These cross-sections are two thin 'slices' of the circuit wires, like the ones we saw above. How are they different?

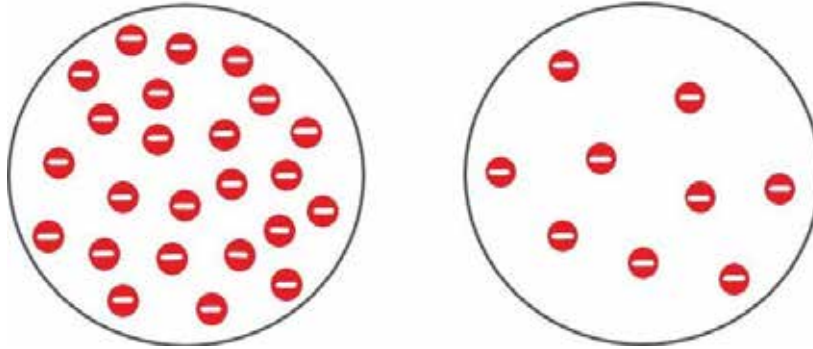

Two 'slices' of wires that have electrical current running through them

The difference you see is the number of electrons that run through each 'slice' of the conductor per second.

**Remember** the model railroad. By clicking on the picture, you can see it move fast. But what happens if the engine cannot pull the carriages very fast? Then, the carriages will move slower; their speed will be lower. If that happens there will be fewer carriages passing through a part of the line every second.

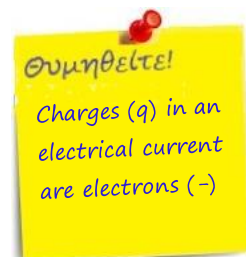

The same is happening with the conductors in the picture above. There are *more* electrons flowing through the 'slice' of the left-hand conductor every second. There are fewer electrons flowing through the 'slice' of the right-hand conductor per second.

The number of electrons flowing through a 'slice' of a conductor every second is called the current **intensity**. We denote intensity with the symbol **I** and we measure it in **Amperes** or **Amps**, for short (**A**).

(picture on the right:

*In mathematical language...*

*Intensity = charge / time)*



Στη γλώσσα των μαθηματικών...

$$\text{Ένταση} = \frac{\text{Φορτίο}}{\text{Χρόνος}}$$

$$I = \frac{q}{t}$$

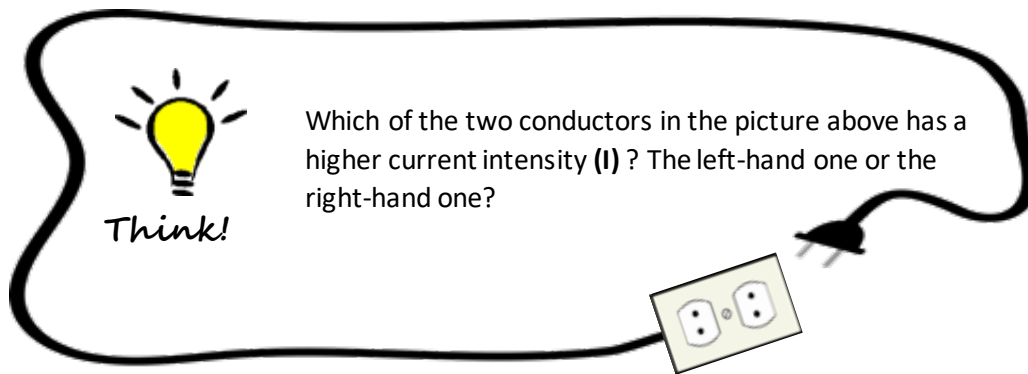

But what makes carriages move faster or slower? In a model train, carriages are powered by a train engine. This pulls them and makes them go faster or slower. In a circuit, the electrons' energy comes from the battery. A battery pushes electrons and makes them go faster or slower.

The amount of energy that a battery provides to an electron is called the **electric potential difference** (or '**voltage**'). The voltage between the two terminals of a battery, or between two points in the circuit is denoted with the symbol **V** and it is measured in Volts (V).

(picture on the right:

*In mathematical language...*

Στη γλώσσα των μαθηματικών...

$$\text{Διαφορά δυναμικού} = \frac{\text{Ενέργεια ηλεκτρική}}{\text{Φορτίο ηλεκτρονίων}}$$



$$V = \frac{E \text{ (ηλεκτρική)}}{q}$$

Electric potential difference = Energy<sub>electric</sub>/Charge<sub>of electrons</sub>)

**Remember!**

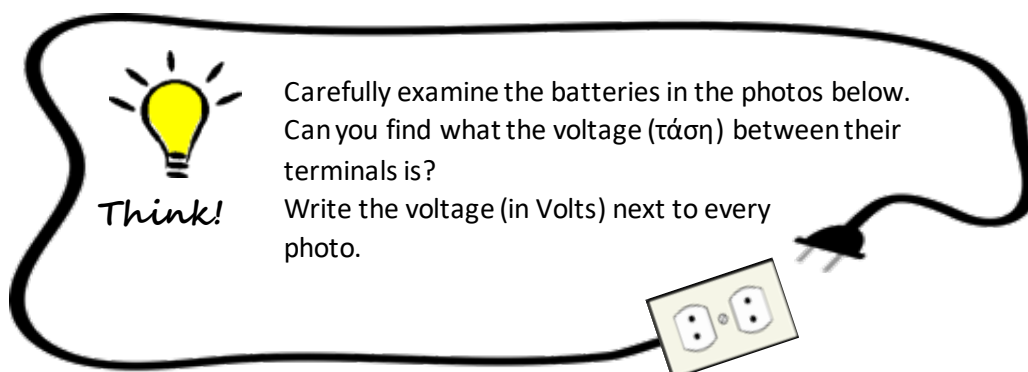
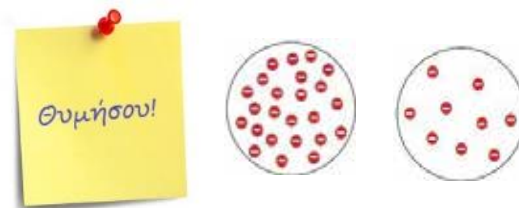
High-voltage (V) batteries generate high current intensity (I). Low-voltage (V) batteries generate low current intensity (I).

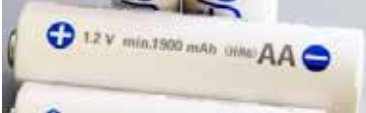

Battery	Voltage (V)
	
	
	
	
	
	
	

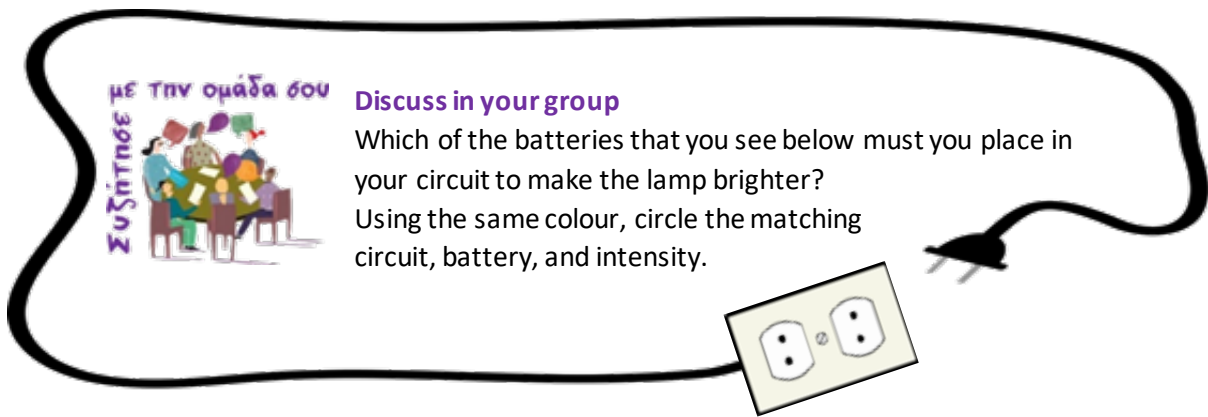

ΜΕ ΤΗΝ ΟΜΑΔΑ ΣΟΥ  
ΣΥΖΗΤΗΣΕ

**Discuss in your group**

Which of the batteries that you see below must you place in your circuit to make the lamp brighter?  
Using the same colour, circle the matching circuit, battery, and intensity.

		<p>low intensity  </p>
		<p>High intensity  </p>

What prevents electrons from flowing?

The current intensity ( $I$ ) does not only depend on the battery. It also depends on the conductor, i.e., the type of wire in a circuit.

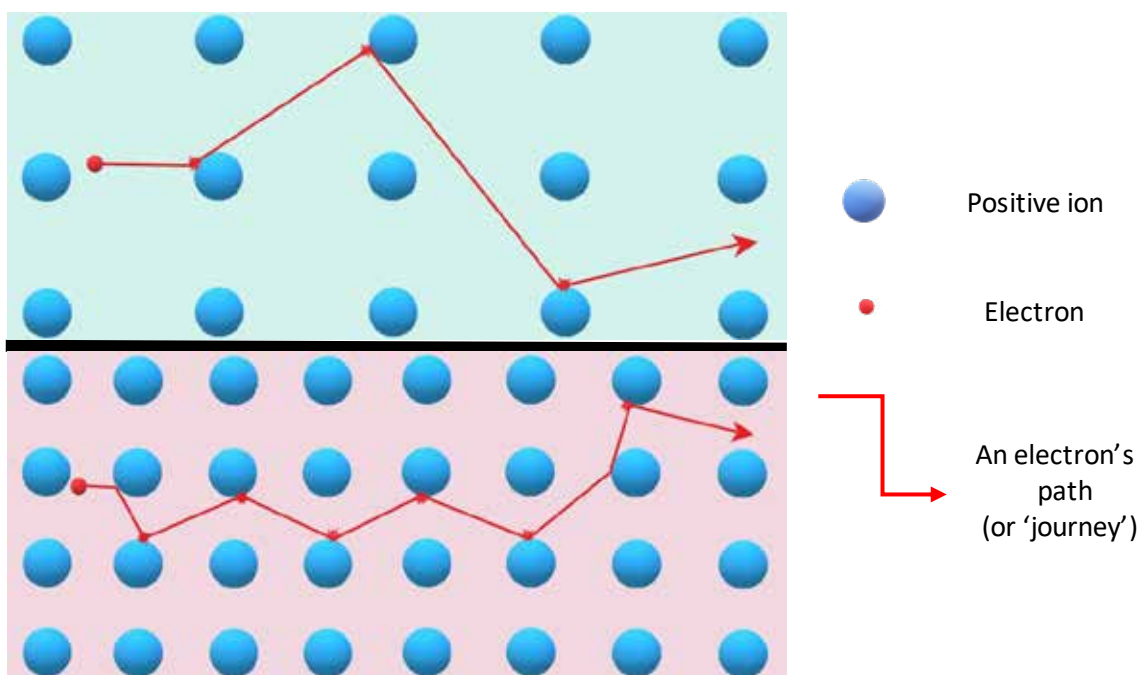
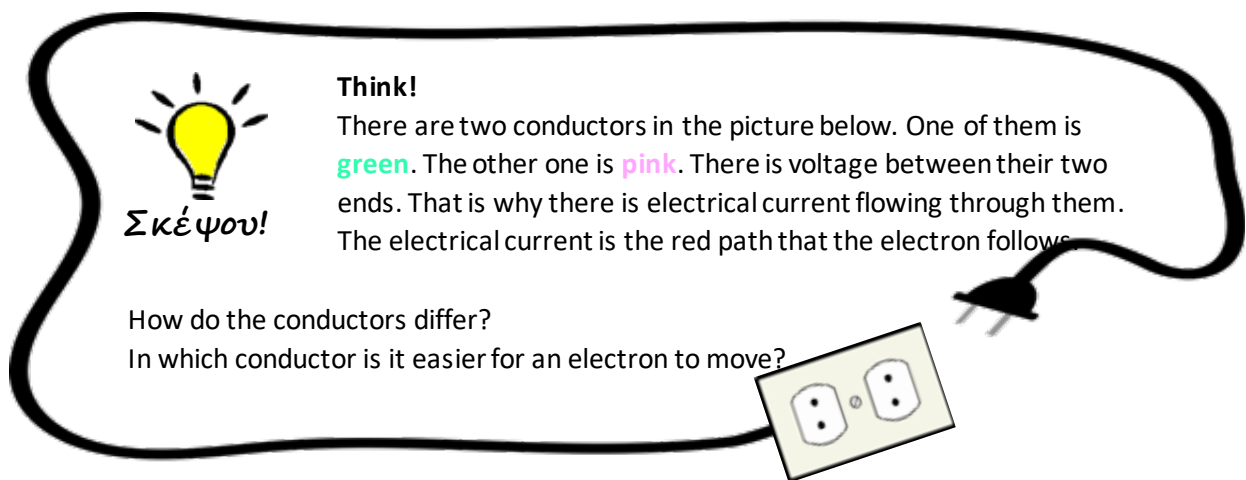

*Two different conductors*

What can we see in the picture? As an electron 'travels', it 'bumps into' the positive ions in the wire. The electron *collides* with the positive ions. This means that the positive ions are making it harder for the electron to move. Every type of conductor can make it easier or harder for an electron to 'travel'. We use the term conductor **resistance**, to name this difficulty in 'travelling'. The *harder* it is for an electron to travel, the greater the conductor resistance is. **Resistance** is symbolized with the letter **R** and it is measured in **Ohms ( $\Omega$ )**.

Imagine that you move your hand close to a lightbulb that is on. You can feel that it is hot. The same happens with all the electrical devices when they are running (working). The same also happens with all the conductors that have an electrical current running through them.

Moving electrons have kinetic energy. As they move, they 'bump into', or *collide with*, the positive ions inside the conductor. This 'crash', or collision, converts the electron's kinetic energy into heat. We use the name **Joule phenomenon** to describe this change.

The higher the resistance of a conductor, the more it is *heated* (i.e., it becomes hotter). A conductor with resistance is called a **resistor**; we use the symbol  to denote resistors.

ΜΕ ΤΗΝ ΟΜΑΔΑ ΣΟΥ  
ΣΥΖΗΤΗΣΕ



**Discuss in your group**

Of the two conductors in the picture above

- ⚡ Which one has a greater resistance?
- ⚡ Which one has a greater current intensity (I)?
- ⚡ Which one will get hotter?

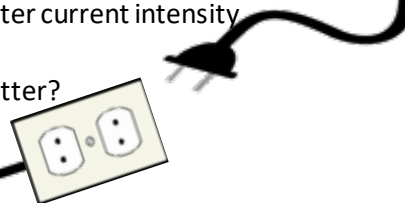



We have already seen that current intensity (I) changes, depending on voltage (V). We now notice that current intensity (I) also changes depending on the conductor's resistance (R).

ΚΑΝΕΙΝΑ ΠΕΙΡΑΜΑ!



Go back to the [virtual electricity lab](#).

Click here  and build a simple circuit. This time add a resistor to your circuit.



Αντιστάτης

Click on the resistor. On the bottom of the screen, slide the blue slider



to the right and left, to change the resistor's resistance. What have you noticed? When do the electrons move faster? Complete the following sentences with the right words.



Electrons move faster when the resistance is .....

Electrons move slower when the resistance is .....



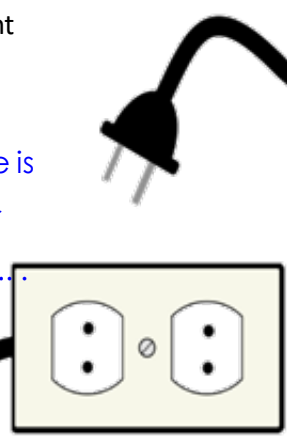





Discuss in your group

Click [here](#) to do an experiment. Select the voltage and resistance that is written in the table. Use the central column (current intensity) to write down the number that you see in the box labelled 'current' (Ρεύμα). What happens to the current intensity when you change the voltage? What happens to the current intensity when you change the conductor's resistance?

Voltage V (Volt)	Current intensity I (mA)	Resistance R (Ω)
1,5		100
1,5		300
1,5		500
1,5		750
3		100
3		300
3		500
3		750
4,5		100
4,5		300
4,5		500
4,5		750
9		100
9		300
9		500
9		750

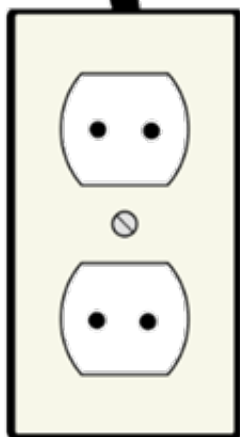

Write down what you saw in the experiment:

⚡ When the resistance is higher (and voltage remains constant), current intensity becomes .....

⚡ When the voltage is higher (and the resistance remains higher), current intensity becomes .....

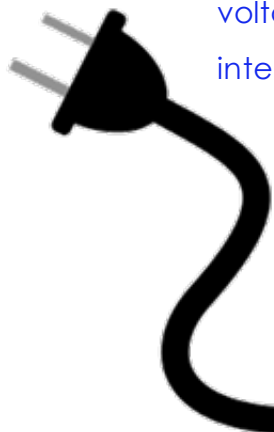



What have we learnt from this experiment? Let's see this in pictures, words, words, and symbols.

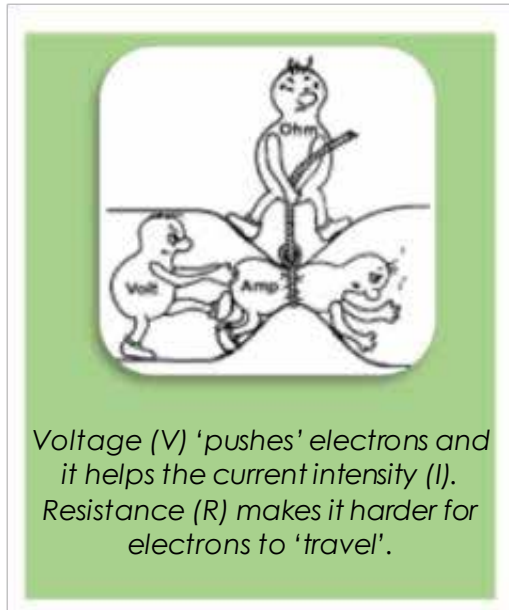

Στη γλώσσα των μαθηματικών...

$$\text{Ένταση} = \frac{\text{Διαφορά δυναμικού}}{\text{Αντίσταση}}$$

$$I = \frac{V}{R}$$

Intensity  
= potential difference / resistance

### One current, multiple paths...

There are two, three, or more resistors in every real-life circuit. Resistances connect in several different ways. Let's see two examples.

When the electrical current meets two resistors in the same path, and these resistances are placed one after the other, we say that these resistors are a **series resistor network**. Every electron finds it *twice as hard* to pass, because it meets *two* obstacles: resistor  $R_1$  **and** resistor  $R_2$ .

But if the electrical current can *either* follow a path with one resistor ( $R_1$ ), *or* a different path with *another* resistor (την  $R_2$ ), then we saw that these resistors form a **parallel resistor network**. Every electron will only find it hard to flow *once*, because it will meet just *one* obstacle: resistor  $R_1$  **or** resistor  $R_2$ .

We want to calculate the resistance of the circuit as a whole. We call this the *total* resistance (R). A circuit with a series resistor network will have a total resistance (R) that is greater than the resistance of each separate resistor ( $R_1, R_2$ ). In a circuit with a parallel resistor network, the total resistance (R) is *less* than the resistance of each separate resistor ( $R_1, R_2$ ).

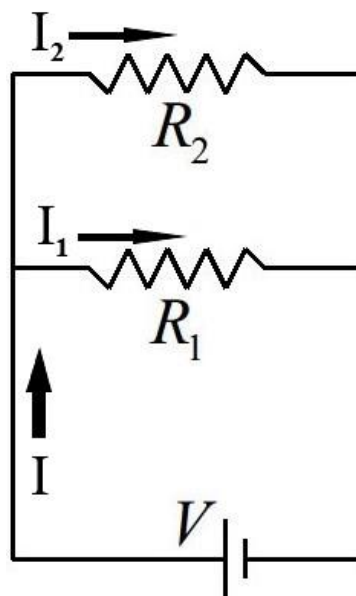
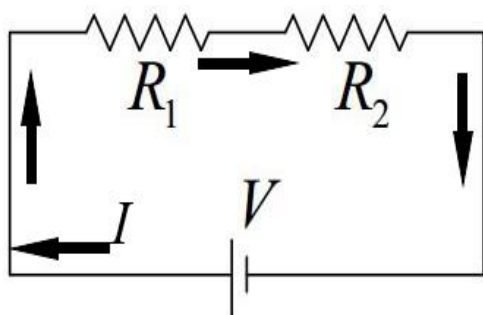
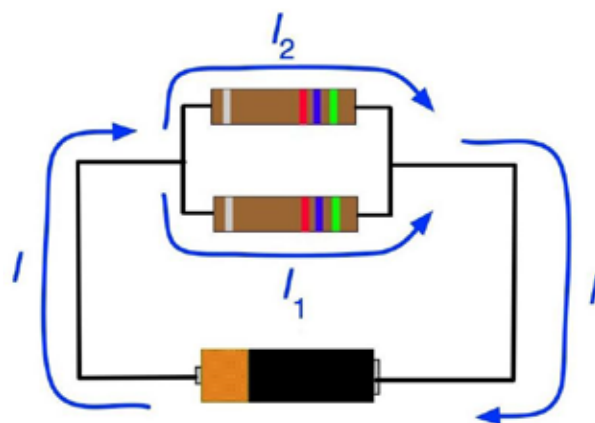
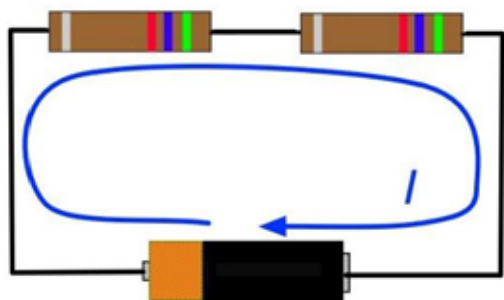



 Στη γλώσσα των μαθηματικών...

$$R = R_1 + R_2$$

Για παράδειγμα, αν  $R_1=10 \Omega$  και  $R_2=10 \Omega$ , τότε

Two resistors connected serially

For example, if  $R_1 = 10 \Omega$  and  $R_2 = 20 \Omega$ , then

 Στη γλώσσα των μαθηματικών...

$$R = \frac{1}{R_1} + \frac{1}{R_2}$$

Για παράδειγμα, αν  $R_1=10 \Omega$  και  $R_2=10 \Omega$ , τότε

$$R = \frac{1}{10} + \frac{1}{10} = \frac{2}{10} = 0,2 \Omega$$

Two resistors connected in parallel

For example, if  $R_1 = 10 \Omega$  and  $R_2 = 20 \Omega$ , then



Click [here](#)

1. Build a circuit with a lightbulb and two resistors in a series

network. If you click on every resistor,  a window

 will appear on the bottom of the screen

where you can lower its resistance. You can do the same with the lightbulb by clicking on it . Lightbulbs have resistance too!

⚡ What will happen if you increase both resistances? Fill in the gap, by choosing the right word from the ones in the brackets near each sentence.

Electrons move ..... (faster / slower)

The lightbulb is ..... (brighter / less bright)

⚡ Why do you think that happens?

This happens because the total resistance of the circuit has

..... (increased / decreased) and it is now

..... (easier / harder) for the current to flow.

⚡ Can the circuit still work if you remove a resistor? Does the lightbulb stay on? ..... (Yes /No).

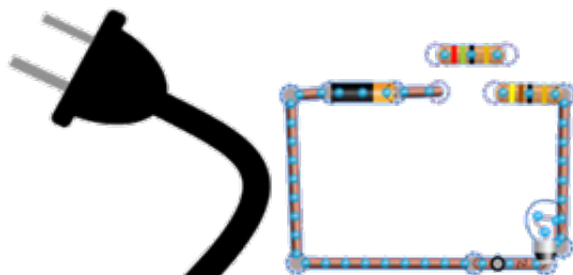
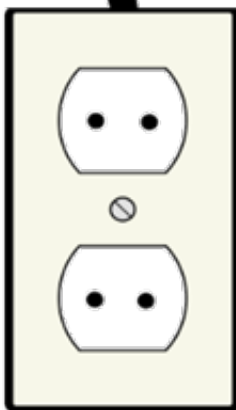



**Do this exercise**

Imagine a circuit with two resistors. One resistor has a resistance  $R_1 = 30 \Omega$ . The other one has a resistance  $R_2 = 60 \Omega$ .

The resistors are connected in a series network. What is the total resistance of the circuit?

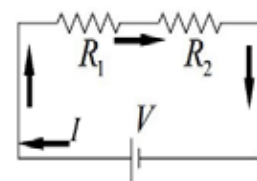

What do I know?	What do I need?	What am I looking for?
$R_1 = 30 \Omega$ $R_2 = 60 \Omega$	$R = R_1 + R_2$	<b>R</b>

$$R = R_1 + R_2$$

$$R = \dots + \dots$$

$$R = \dots \Omega$$

Now the resistors are connected in a parallel network. What is the total resistance of the circuit?

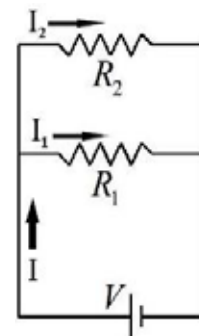

What do I know?	What do I need?	What am I looking for?
$R_1 = 30 \Omega$ $R_2 = 60 \Omega$	$R = \frac{1}{\frac{1}{R_1} + \frac{1}{R_2}}$	<b>R</b>

$$R = \frac{1}{\dots} + \frac{1}{\dots}$$

$$R = \dots$$

$$R = \dots \Omega$$



### What have we learnt?

In this chapter, we learnt that:

1. A lot of things that we use every day need an electrical current to work. Also, a lot of devices we use run on electricity.
2. **An electrical current** is electrons moving in the same direction.
3. Electrical currents flow in **conductors**. Conductors are materials with free electrons. Iron, copper, and aluminium are conductors.
4. An electrical current can only flow in a **closed circuit**. A circuit is the path that electrons travel in. In a circuit we will find: conductors, a source, and something (like a lightbulb) that operates on electrical current.
5. A **source** gives electrons energy which makes them move fast in a circuit. A battery is an example of an electric source.
6. Devices have switches, which keep them from running constantly. When we press on a switch, this open (breaks) or closes a circuit. A device works when the circuit is closed. It stops working when the circuit is open.
7. The **current intensity** is how many electrons ( $q$ ) move through a 'slice' of the conductors every second. We use the symbol **I** to denote intensity, and we measure it in **Ampere(s)/Amp(s) (A)**.

$$I = \frac{q}{t}$$

8. The **electric potential difference** (or **voltage**) is the amount of energy that a source (battery) gives to each electron so that it can move in a circuit. We denote voltage with the symbol **V** and measure it in **Volts (V)**.

$$V = \frac{E}{q}$$

9. The **resistance** is how much a conductor makes it hard for electrons to move between positive ions. We denote resistance with the symbol **R** and we measure it on **Ohm(s) ( $\Omega$ )**. The *higher* a conductor's resistance, the smaller the current intensity in this conductor.

$$I = \frac{V}{R}$$

10. The resistors in a circuit can be conducted in a *series network*. To find the total resistance ( $R$ ) of the circuit we need to *add* all the resistances.

$$R = R_1 + R_2$$

11. The resistors in a circuit can be conducted in a *parallel network*. The total resistance ( $R$ ) of the network is *less* than each separate resistance. It equals

$$R = \frac{1}{R_1} + \frac{1}{R_2}$$

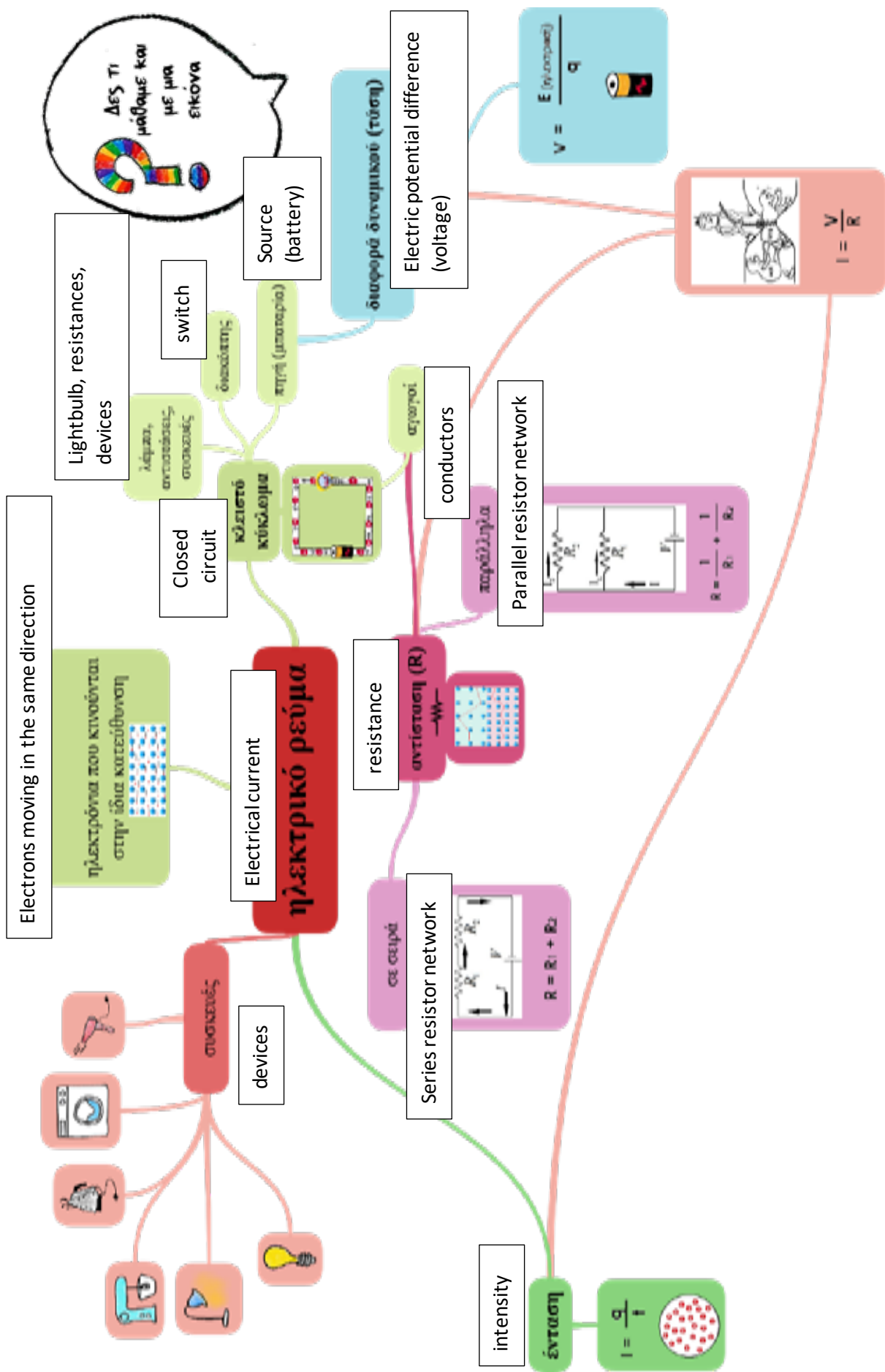





Φυσική  
Γλωσσάρι



Physics  
Glossary



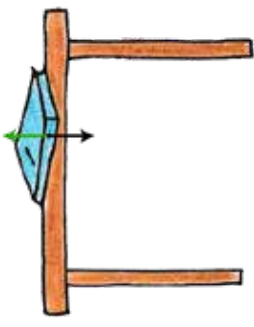

# Glossary<sup>1</sup>

scientific word / In English	scientific word / .... / επιστημονική λέξη		What does it mean?	What does it mean? (Written in the target language)	Example / ... / Παράδειγμα	Symbol Σύμβολο	Unit Μονάδα μέτρησης
	In your language	Στα ελληνικά					
atom		άτομο	The smallest part of a substance, which we cannot divide into smaller ones. It has a nucleus with protons and neutrons. Electrons orbit around the nucleus. It is electrically neutral. <i>(Picture on the right: ηλεκτρόνιο, νετρόνιο, πυρήνας, πρωτόνιο: Electron, νετρόνιο: Neutron, πυρήνας: Nucleus, πρωτόνιο: Proton)</i>				
balancing forces		αντίθετες δυνάμεις	The forces on an object, which are equal in measure and opposite in direction. Balancing forces cancel each other out, they have a resultant force equal to 0.			F	Newton (N)

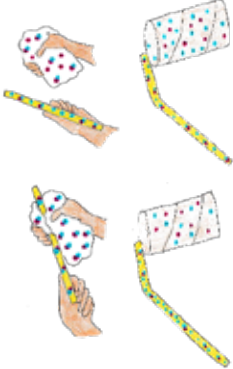
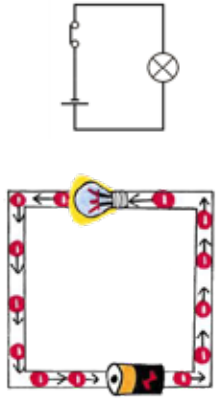
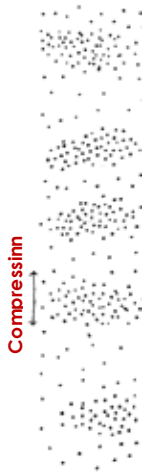

<sup>1</sup> Fill in the 2<sup>nd</sup> and 5<sup>th</sup> columns as well as everything that is highlighted in purple in your own language.

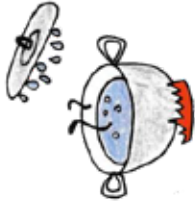
boiling		βρασμός	The change from a liquid to a gas. The liquid takes heat from the fire or the hotplate. Boiling happens fast.				
---------	--	---------	---	--	---	--	--

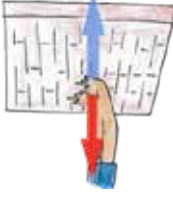
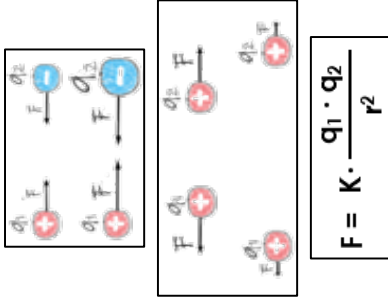

scientific word / In English	In your language	Scientific word / In your language / Στα ελληνικά	What does it mean?	What does it mean? (Written in the target language)	Example / .... / Παράδειγμα	Symbol	Unit
charging		ηλέκτριση	When something which was neutral gains, or loses, electrons, and becomes electrically charged. It can happen through friction or contact.	What does it mean? (Written in the target language)		Σύμβολο	Μονάδα μέτρησης
circuit		κύκλωμα	A route of conductors. An electrical current might move through it. For an electrical current to exist, a circuit must be closed.	What does it mean? (Written in the target language)			
compression		πύκνωμα	In a sound wave, this is where the air molecules are very dense, closer to each other.	What does it mean? (Written in the target language)			

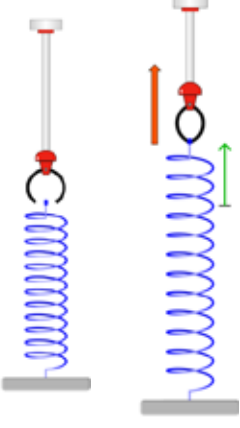
condensation	υγροποίηση	Change from a gas from to liquid. A gas loses heat and becomes a liquid.			Example / ... / Παράδειγμα	Symbol ..... Σύμβολο	Unit ..... Μονάδα μέτρησης
scientific word / .... / επιστημονική λέξη	In your language ..... Στα ελληνικά	What does it mean?	What does it mean? (Written in the target language)				
conductor	αγωγός	A material that allows electrical current to move through it.					
contact forces	δυνάμεις με επαφή	These are forces that are applied when the interacting objects are in contact with each other.					
Coulomb's law	νόμος του Coulomb	The electric force between two charges is <ul style="list-style-type: none"> <li>• Proportional to the product of the two charges</li> <li>• Inversely proportional to the square of the distance between the two charges</li> </ul>					

<b>current</b>		ένταση ηλεκτρικού ρεύματος	How many electrons can pass through a 'slice' of a conductor in a second.			I	<b>Ampere (A)</b>
----------------	--	----------------------------	---	--	---	---	-------------------

scientific word / .... / επιστημονική λέξη	In your language	What does it mean?	What does it mean? (Written in the target language)	Example / .... / Παράδειγμα	Symbol	Unit
In English						Μονάδα μέτρησης
<b>deformation</b>			When a thing changes shape.			
<b>displacement</b>			The difference between the final position ( $x_2$ ) of a moving object and its original position ( $x_1$ ).		$\Delta x$	<b>Meters (m)</b>

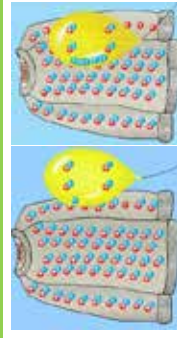
distance forces		δυνάμεις από απόσταση	The forces that are applied when the interacting objects are not in contact with each other.				
ηλεκτρικό φορτίο		electric charge	What makes things attract or repel each other without being in contact. An electrical charge is positive or negative.		q	Coulomb (C)	

scientific word / .... / επιστημονική λέξη	In your language		What does it mean?	What does it mean? (Written in the target language)	Example / .... / Παράδειγμα	Symbol	Unit
	In English	Στα ελληνικά					
electric charge conservation principle		αρχή της διατήρησης του φορτίου	The total number of charges does not change. It remains constant.				
electric current		ηλεκτρικό ρεύμα	Free electrons that move in the same direction in a closed circuit.				

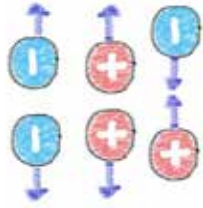
electric energy	ηλεκτρική ενέργεια	The energy that electrical appliances use in our homes. We pay for electrical energy in our electricity bills.		Κιλοβατώρα (KWh)
electric forces	ηλεκτρικές δυνάμεις	Forces that are applied among electrical charges. They are forces from a distance.		Newton (N)

scientific word / ..... / επιστημονική λέξη	In your language	What does it mean?	What does it mean? (Written in the target language)	Example / ... / Παράδειγμα	Symbol	Unit
electricity source	πηγή ηλεκτρικού ρεύματος	Something (e.g., a battery) that gives energy to electrons, to make them move in a closed circuit.	What does it mean? (Written in the target language)		Σύμβολο	Μονάδα μέτρησης
electron	ηλεκτρόνιο	The smallest negative charge. All atoms have electrons that move around their nucleus. An electron's charge is the opposite of a proton's.	What does it mean? (Written in the target language)			

energy									Joule (J)
energy conservation principle									

(Picture on the right:  
ηλεκτρόνιο: Electron,  
νετρόνιο: Neutron,  
πυρήνας: Nucleus,  
πρωτόνιο: Proton)

Something that changes the forms of things and causes them to change. Some forms of energy are: chemical, solar, electric, thermal, light, and mechanical energy.

The total energy does not change. It is conserved.  
(Picture on the right:  
Τριβή: Friction)

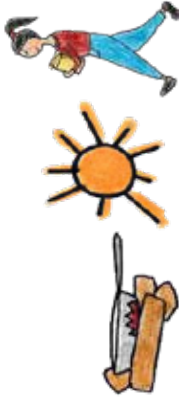

scientific word / .... / επιστημονική λέξη										
In English	In your language	Στα ελληνικά								
evaporation		εξάτμιση								

What does it mean?  
The change from a liquid to a gas. A liquid takes heat from the environment. Evaporation happens slowly.

What does it mean?  
The change from a liquid to a gas. A liquid takes heat from the environment. Evaporation happens slowly.

Example / ... / Παράδειγμα

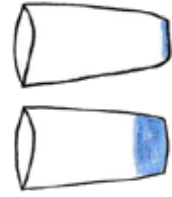

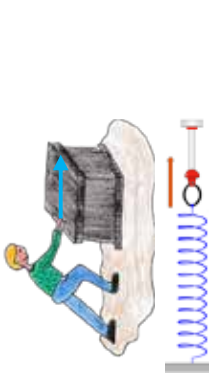
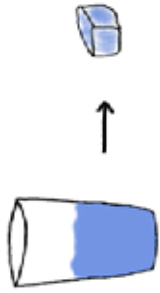
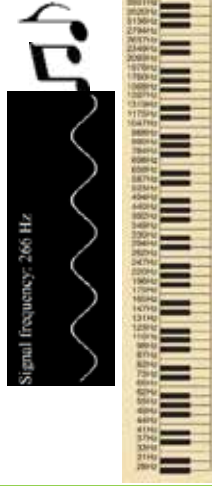

Symbol  
Σύμβολο

Unit  
Μονάδα μέτρησης

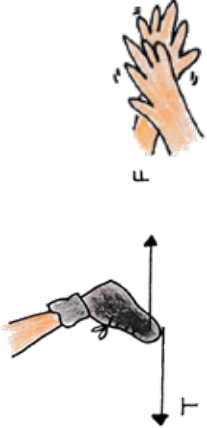
force	δύναμη	When we push or pull something. A force can change the movement or shape of things.		F	Newton (N)
freezing	πήξη	The change of a liquid to a solid. The liquid loses heat and becomes a solid.			
frequency	συχνότητα	How many oscillations the source of a sound makes per second		f	Hertz (Hz)

scientific word / ... / επιστημονική λέξη	Unit	Μονάδα μέτρησης	Symbol	Σύμβολο	Example / ... / Παράδειγμα	Newton (N)
In English	In your language	Στα ελληνικά				
friction		τριβή	What does it mean?	What does it mean? (Written in the target language)	A force that resists, or makes harder, the movement of one thing on another one.	

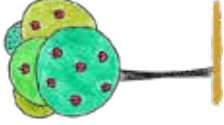

gases	αέρια	Things that change their shape and volume. Gases fill in all the space around them. Molecules in gases move freely.			
gravitational potential energy	βαρυτική δυναμική ενέργεια	The potential energy that things have because the earth's gravity pulls them downwards.		U	Joule (J)
heat	θερμότητα	Energy that 'travels' from a warm object to a cooler one.			

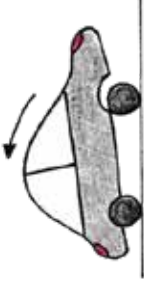
scientific word / ..... / επιστημονική λέξη	In your language	What does it mean?	What does it mean? (Written in the target language)	Example / .... / Παράδειγμα	Symbol	Unit
inertia	In your language	Things try not to change their speed. If they are at rest, they try to stay at rest. If they are moving, they try to continue their movement at the same speed.			Σύμβολο	Μονάδα μέτρησης
	Στα ελληνικά	αδράνεια				

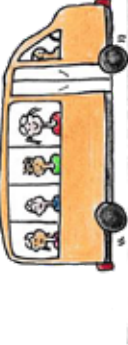
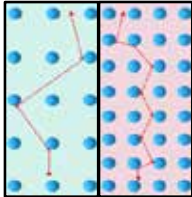
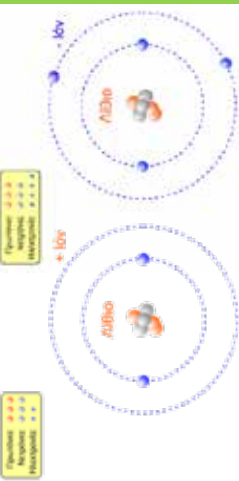

kinetic energy		κινητική ενέργεια	The energy of a moving thing. It is a form of mechanical energy.			E <sub>k</sub>	Joule (J)
Joule effect	φαινόμενο Joule	φαινόμενο Joule	When electricity runs through a conductor, the conductor gets warm.				
ion	ιόν	ιόν	An atom that has lost, or gained, electrons. It is not electrically neutral. (Picture on the right: Πρωτόνια: Protons Νετρόνια: Neutrons Ηλεκτρόνια: Electrons, Λίθιο: Lithium Ιόν: Ion)				

scientific word / .... / επιστημονική λέξη	What does it mean?	What does it mean?	What does it mean? (Written)	Example / ... / Παράδειγμα	Symbol	Unit
--	--------------------	--------------------	------------------------------	----------------------------	--------	------



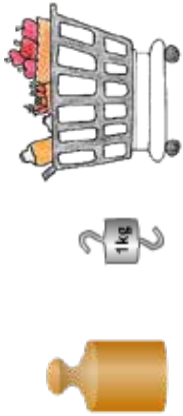
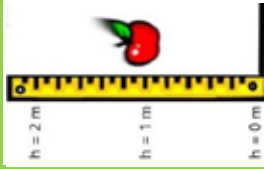

# GLOSSARY

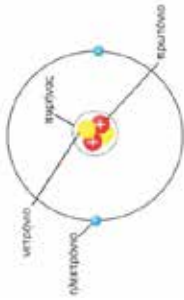
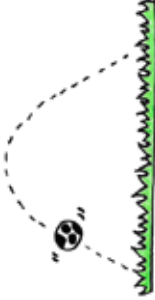

In English	In your language	Στα ελληνικά	In the target language)	in the target language)	Σύμβολο	Μονάδα μέτρησης
length of path		μήκος της διαδρομής	The distance between positions $x_1$ and $x_2$ in a moving object.		s	Meters (m)
like charges		ομώνυμα φορτία	Charges that are the same. Like charges repel (move away from) each other.			
liquids		υγρά	Things which can change their shape. The volume in liquids is always the same. Molecules in liquids are close to each other and roll over each other.			
loudness		ακουστότητα	How strong or low a sound is heard. Sounds with a high loudness are louder.			

scientific word / ... / επιστημονική λέξη	What does it mean?	Example / ... / Παράδειγμα	Symbol	Unit
---	--------------------	----------------------------	--------	------



In English	In your language	Στα ελληνικά	in the target language)	Εμφάνιση	Σύμβολο	Μονάδα μέτρησης
mass		μάζα	The measurement that tells us if something is made of a lot or a little material.		m	Kilogram (kilo) kg
mechanical energy		μηχανική ενέργεια	The sum of potential and kinetic energy of a thing. It is always the same; it remains stable.		Emechanical	Joule (J)
melting		τήξη	Change from solid form to liquid. A solid object absorbs heat and melts, it becomes a liquid.			
motion		κίνηση	When something changes its position, when it moves from one place to another.			

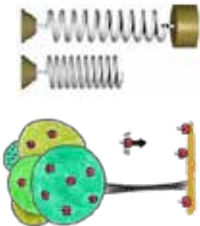
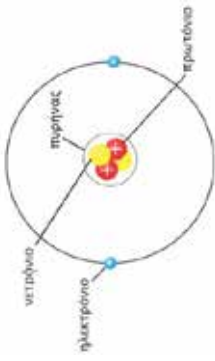

scientific word / ..... / επιστημονική λέξη	What does it mean?	Example / ... / Παράδειγμα	Symbol	Unit
---	--------------------	----------------------------	--------	------

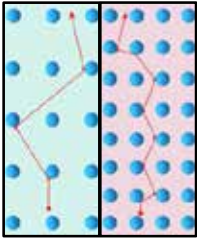

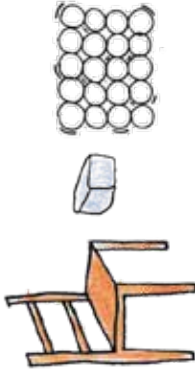
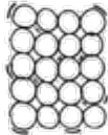
In English	In your language	Στα ελληνικά	in the target language)	..... Μονάδα μέτρησης	..... Σύμβολο
neutron		νετρόνιο	A small particle that is in the nucleus of atoms. It does not have an electric charge. (Picture on the right: ηλεκτρόνιο: Electron, νετρόνιο: Neutron, πυρήνας: Nucleus, πρωτόνιο: Proton)		
orbit		τροχιά	A line that connects all the points from where a moving object passes.		
oscillation		ταλάντωση	When something makes a small movement around its position.		
pitch		ύψος ήχου	How high or low a sound is. Low frequency sounds have the lowest pitch. High frequency sounds have the highest pitch.		
potential difference (voltage)		διαφορά δυναμικού (τάση)	How much energy a source (battery) gives to an electron to make it move in a circuit.		Volt (V)

scientific word / .... / επιστημονική λέξη		What does it mean?	Example / ... / Παράδειγμα	Symbol Σύμβολο	Unit Μονάδα μέτρησης
In English	In your language Στα ελληνικά				
potential energy	δυναμική ενέργεια	The energy that things have because they are in a place, or because their shape has changed (they have been distorted). It is a form of mechanical energy.		U	Joule (J)
proton	πρωτόνιο	The smallest positive charge (+). All atoms have protons in their nucleus. A proton's charge is the opposite of an electron's. (Picture on the right: ηλεκτρόνιο: Electron, νετρόνιο: Neutron, πυρήνας: Nucleus, πρωτόνιο: Proton)			
rarefaction	αραιώμα	In a soundwave this is where the air molecules are thinner, farther away from each other.			

resistance	ανίσταση	How much a conductor makes it harder for electrons to move through it.		R	Ohm (Ω)
------------	----------	--	---	---	---------

scientific word / ... / επιστημονική λέξη	What does it mean?		What does it mean? (Written in the target language)	Example / ... / Παράδειγμα	Symbol ..... Σύμβολο	Unit ..... Μονάδα μέτρησης
	In your language	Στα ελληνικά				
resistor		A conductor with a resistance.				
resultant force						
solids		Things that do not change a shape and always have the same volume. Molecules of solid objects are very close to each other and move very little.				
sound		Something that we hear with our ears. Sound is a wave. It begins at a source and travels through a material medium.				

sound intensity		ένταση του ήχου	How loud a sound is.		Decibel (dB)
sound propagation		διάδοση του ήχου	The movement of sound through a medium such as air.		

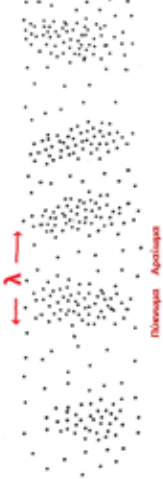
scientific word / ... / επιστημονική λέξη	What does it mean?	What does it mean? (Written in the target language)	Example / ... / Παράδειγμα	Symbol Σύμβολο	Unit Μονάδα μέτρησης
In English					
	Στα ελληνικά				
sound propagation medium	What does it mean? A material (solid, liquid or gas) through which sound travels, (is propagated). Most of the sounds that we hear are propagated through air.	What does it mean? (Written in the target language)			
sound source	What does it mean? Something (e.g. a string) that makes a sound.	What does it mean? (Written in the target language)			
sound wavelength	What does it mean? In a soundwave, this is the distance between one compression and the next, and between one rarefaction and the next.	What does it mean? (Written in the target language)		λ	Meters (m)



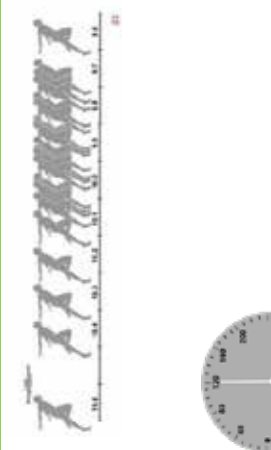

speed	ταχύτητα	(Picture on the right: Πύκνωμα: Compression, Αραίωμα: Rarefaction)	How fast something moves		u	Meters per second (m/s)
-------	----------	--	--------------------------	---	---	-------------------------

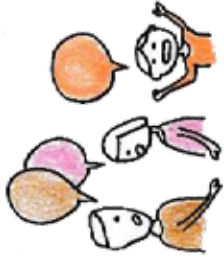
scientific word / ... / επιστημονική λέξη	In your language	What does it mean?	What does it mean? (Written in the target language)	Example / ... / Παράδειγμα	Symbol	Unit
In English	στα ελληνικά					
speed of sound	ταχύτητα του ήχου	How fast sound moves through a solid, liquid or gas medium.	What does it mean? (Written in the target language)		u	Meters per second (m/s)
temperature	θερμοκρασία	The measurement that tells us if something is warm or cold.	What does it mean? (Written in the target language)		θ	Degree Celsius (°C)

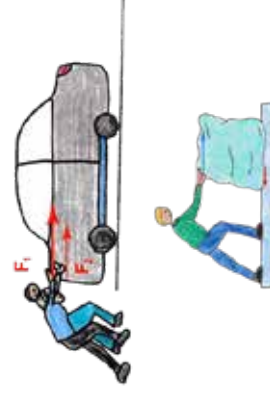
thermal equilibrium		Θερμική ισορροπία	When two things that are in contact reach the same temperature. The warmer object transmits heat to the cooler one.		
fimbre		χροιά ήχου	What allows us to distinguish one sound from another, even if they have the same pitch and volume.		

scientific word / ... / επιστημονική λέξη	In your language	Στα ελληνικά	What does it mean?	What does it mean? (Written in the target language)	Example / ... / Παράδειγμα	Symbol	Unit
time interval		Χρονικό διάστημα	Πόσο χρόνο κράτησε μια αλλαγή, για παράδειγμα μια κίνηση.			$\Delta t$	Δευτερόλεπτο (s) Μονάδα μέτρησης
total force		συνισταμένη δύναμη	The total force that is applied on a thing from all the other objects with which it interacts.			$F_{\text{ολ}}$	Newton (N)

trajectory	τροχιά	A line that connects all the points from where a moving object passes.				
unlike charges	ετερόνυμα φορτία	Different charges, i.e., a positive and a negative one. Unlike charges attract.				
water cycle	κύκλος του νερού	When water changes forms in nature. This is how clouds, rain, hail, sleet, and snow are created.				

scientific word / ... / επιστημονική λέξη	Unit	Symbol	Example / ... / Παράδειγμα	What does it mean? (Written in the target language)	What does it mean?	What does it mean?
In English	Μονάδα μέτρησης	Σύμβολο				
water vapor					Water in gas form.	υδρατμός

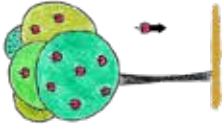
<b>weight</b>		<b>βάρος</b>	The force that the earth applies on things and pulls them towards its centre.			w	<b>Newton (N)</b>
---------------	--	--------------	---	--	---	---	-------------------





Funded by the  
Asylum, Migration and  
Integration Fund of the  
European Union



ΠΑΝΕΠΙΣΤΗΜΙΟ  
ΘΕΣΣΑΛΙΑΣ



Αυτή η έκδοση χρηματοδοτήθηκε από την Ευρωπαϊκή Ένωση. Το περιεχόμενό της εκφράζει τις απόψεις των συγγραφέων της και δεν μπορεί να θεωρηθεί ότι αντικατοπτρίζει την επίσημη θέση της Ευρωπαϊκής Ένωσης.